

T95

900 kg · 900 kg

IT Unico sul mercato, il Traker T95 è il modello dalle prestazioni e caratteristiche senza eguali. Trasportare fino a 900 kg di materiale non è mai stato così facile. La doppia pompa a portata variabile con mono-joystick rende questa macchina potente e facile da governare, riduce i consumi ed azzerà gli interventi di manutenzione. Il mezzo ideale per grandi carichi di lavoro e flotte noleggio.

FR Unique sur le marché, le Traker T95 représente un modèle avec des performances et caractéristiques sans précédent. Il n'a jamais été aussi facile de transporter jusqu'à 900 kg de matériel. La double pompe à débit variable avec levier de commande unique rend cette machine puissante et facile à diriger, elle réduit la consommation et élimine les interventions de maintenance. Le moyen idéal pour les charges de chantier lourdes et les flottes de location.

Sovraspanda
Rallonge



Sottocarro rinforzato
Châssis porteur renforcé

Joystick



Cofano posteriore con apertura laterale
per facilitare gli interventi di manutenzione
Capot arrière avec ouverture latérale
pour faciliter les interventions de maintenance

T95 • MINIDUMPER

CNF—ÉQUIPEMENT DE CONSTRUCTION

6



SL



HT



HTSL



A



SW

Versioni disponibili · Versions disponibles

1

Motorizzazione diesel o benzina
Diesel ou essence

2

Avviamento elettrico
Démarrage électrique

3

Due pompe port. var. + 1 pompa ingr.
Deux pompes à débit var. + 1 pompe à engr.

4

Trasmissione idrostatica
Transmission hydrostatique

5

Rulli oscillanti
Rouleaux oscillants

VANTAGGI / AVANTAGES



Cassone con sponde apribili
Conteneur avec ridelles ouvrantes



Altezza max 1420 mm
Hauteur max 1 420 mm



Pedana ammortizzata
Plateau d'amortissement

› T95 SWIVEL

La versione SW è adatta a tutti i lavori di movimentazione di materiale dove gli spazi di manovra sono estremamente ridotti. È possibile scaricare frontalmente e lateralmente (destra e sinistra) $\pm 180^\circ$.

La version SW convient à toutes les tâches de manutention de matériel où l'espace de manœuvre est extrêmement réduit. Il est possible de décharger par l'avant et sur les côtés (à droite et à gauche) $\pm 180^\circ$.





Cassone con angoli a 45°
Conteneur avec angles de 45°

Pedana ammortizzata
Plateau d'amortissement



Grande distanza di scarico
Grande distance de déchargement

Supporti di sicurezza
Supports de sécurité

T95

MINIDUMPER

CAPACITÀ OPERATIVA
CAPACITÉS DE FONCTIONNEMENT
900 kg · 900 kg

LARGHEZZA AI CINGOLI
LARGEUR DES CHENILLES
780 mm · 780 mm

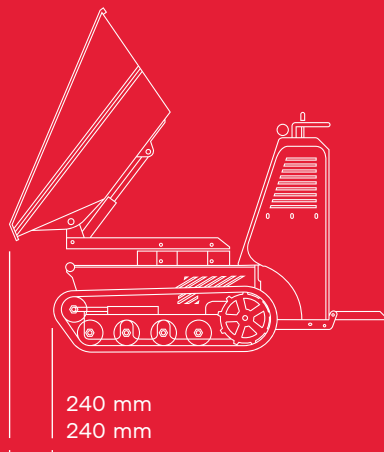
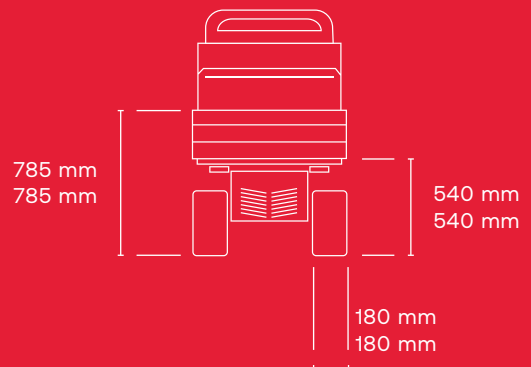
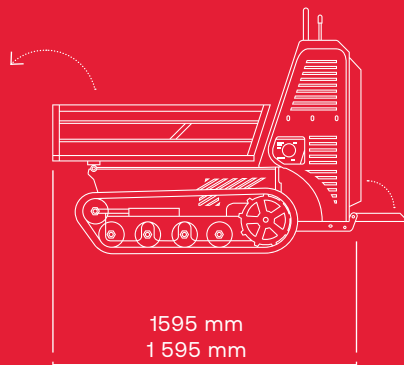
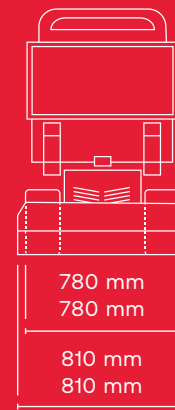

MOTORE TERMICO
MOTEUR THERMIQUE

→ HONDA GX390
→ YANMAR L100

TRASMISSIONE
TRANSMISSION

→ IDROSTATICA
→ HYDROSTATIQUE

POMPA IDRAULICA
POMPE HYDRAULIQUE

→ 2 x PORT. VAR. + 1 POMPA INGR
→ 2 x DÉB. VAR. + 1 POMPE À ENGR.

MOTORE IDRAULICO
MOTEUR HYDRAULIQUE

2 x ORBITALI
2 ORBITAUX

PORTATA POMPA
DÉBIT POMPE

→ 2x32 l/min + 1 POMPA INGR
→ 2x32 L/miN + 1 POMPE À ENGR.

PRESSIONE MASSIMA
PRESSION MAXIMALE

180 bar
180 bars

RAFFREDDAMENTO IDRAULICO
REFROIDISSEMENT HYDRAULIQUE

ARIA
AIR

LARGHEZZA CINGOLI
LARGEUR CHENILLES

180 mm
180 mm

RULLI
ROULEAUX

→ 4

RULLI OSCILLANTI
ROULEAUX OSCILLANTS

SI
OUI

REGOLAZIONE CINGOLI
RÉGLAGE CHENILLES

SI
OUI

VELOCITÀ DI TRASLAZIONE
VITESSES DE TRANSLATION

→ 5 km/h
→ 3.1 mp/h

CAPACITÀ OPERATIVA
CAPACITÉS DE FONCTIONNEMENT

→ 900 kg / 900 kg

EXTRÉMITÉ

→ 800 kg / 800 kg

MASSA A VUOTO
POIDS À VIDE

500 kg
500 kg

CONTROLLO
CONTRÔLE

→ LEVIER DE COMMANDE UNIQUE
DOPPIA LEVA (OPZIONALE)
DOUBLE LEVIER (EN OPTION)

CARATTERISTICHE TECNICHE / CARACTÉRISTIQUES TECHNIQUES

 RASO 0.30 m³
À RAS BORD 0.30 m³

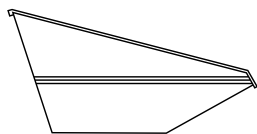

 COLMO 0.36 m³
NOMINALE 0.36 m³

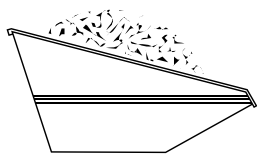

 RASO 0.17 m³
À RAS BORD 0.17 m³

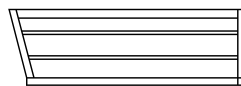

 COLMO 0.25 m³
NOMINALE 0.25 m³

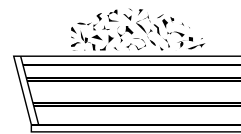

 RASO 0.28 m³
À RAS BORD 0.28 m³

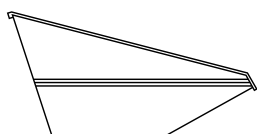

 COLMO 0.36 m³
NOMINALE 0.36 m³

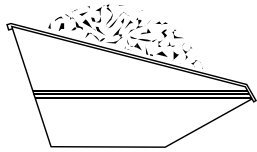

CAPACITÀ / CAPACITÉ



CNF

T95
HIGH TIP

0000
OCF
101







