

T70

700 kg · 700 kg

IT Motore termico più performante e una grande potenza idraulica a tre stadi permettono al minidumper T70 di trasportare facilmente carichi fino a 700 kg. La macchina ideale per essere utilizzata su cantieri edili, giardinaggio, agricoltura o garden design.

FR Un moteur thermique plus performant et une grande puissance hydraulique à trois stades permettent au mini-dumper T70 de transporter facilement des charges allant jusqu'à 700 kg. La machine idéale pour une utilisation sur des chantiers de construction, du jardinage, de l'agriculture ou du paysagisme.

T70 • MINIDUMPER

CNF—ÉQUIPEMENT DE CONSTRUCTION



Sistema autocaricante
Système de chargement
automatique



Joystick

Sottocarro rinforzato
Châssis porteur renforcé

Equipaggiato con / Équipé de :
Honda 8.4 HP

5



Versioni disponibili · Versions disponibles

1

Motorizzazione a benzina
Moteur à essence

2

Avviamento elettrico
Démarrage électrique

3

Due pompe port. var. + 1 pompa ingr.
Deux pompes à débit var. + 1 pompe à engr.

4

Trasmissione idrostatica
Transmission hydrostatique

5

Rulli oscillanti
Rouleaux oscillants

VANTAGGI / AVANTAGES



Cassone con sponde apribili
Conteneur avec ridelles ouvrantes



Sovraspanda
Rallonge



T70

MINIDUMPER

CAPACITÀ OPERATIVA
CAPACITÉS DE FONCTIONNEMENT
700 kg · 700 kg

LARGHEZZA AI CINGOLI
LARGEUR DES CHENILLES
680 mm · 680 mm

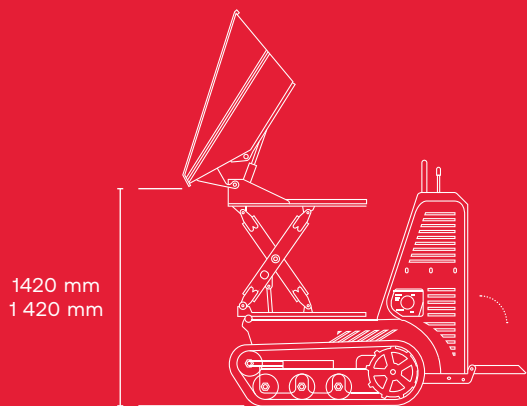
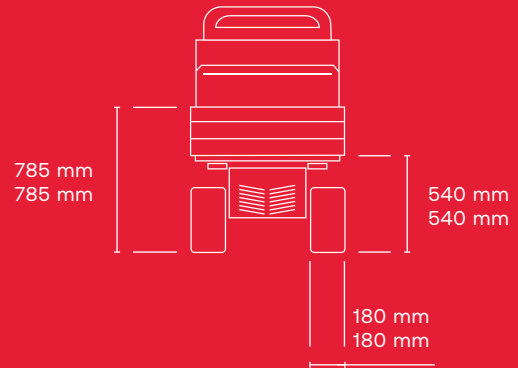
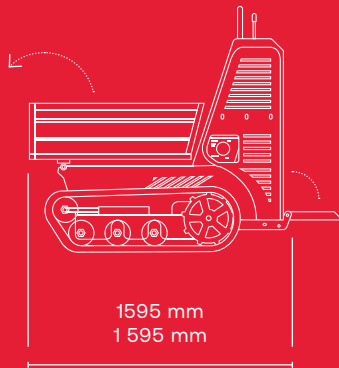
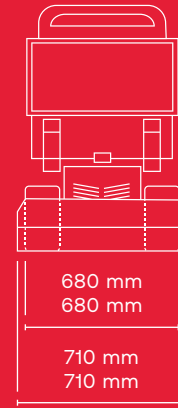
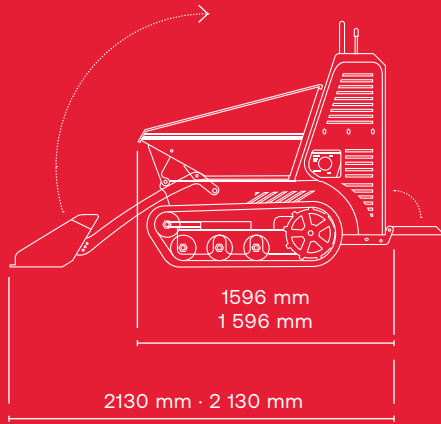

MOTORE TERMICO
MOTEUR THERMIQUE

→ HONDA GX270

TRASMISSIONE
TRANSMISSION

→ IDROSTATICA
→ HYDROSTATIQUE

POMPA IDRAULICA
POMPE HYDRAULIQUE

→ 2 x PORT. VAR. + 1 POMPA INGR.
→ 2 x DÉB. VAR. + 1 POMPE À ENGR.

MOTORE IDRAULICO
MOTEUR HYDRAULIQUE

2 x ORBITALI
2 ORBITAUX

PORTATA POMPA
DÉBIT POMPE

2x32 l/min + 1 POMPA INGR.
2x32 L/miN + 1 POMPE À ENGR.

PRESSIONE MASSIMA
PRESSION MAXIMALE

180 bar
180 bars

RAFFREDDAMENTO IDRAULICO
REFROIDISSEMENT HYDRAULIQUE

ARIA
AIR

LARGHEZZA CINGOLI
LARGEUR CHENILLES

180 mm
180 mm

RULLI
ROULEAUX

3

RULLI OSCILLANTI
ROULEAUX OSCILLANTS

→ SI
→ OUI

REGOLAZIONE CINGOLI
RÉGLAGE CHENILLES

SI
OUI

2 VELOCITÀ DI TRASLAZIONE
2 VITESSE DE TRANSLATION

5 km/h
5 km/h

CAPACITÀ OPERATIVA
CAPACITÉS DE FONCTIONNEMENT

→ 700 kg / 700 kg

EXTRÉMITÉ

→ 600 kg / 600 kg

MASSA A VUOTO
POIDS À VIDE

450 KG
450 KG

CONTROLLO
CONTRÔLE

→ LEVIER DE COMMANDE UNIQUE
DOPPIA LEVA (OPZIONALE)
DOUBLE LEVIER (EN OPTION)

CARATTERISTICHE TECNICHE / CARACTÉRISTIQUES TECHNIQUES

 RASO 0.24 m³
À RAS BORD 0.24 m³

 COLMO 0.30 m³
NOMINALE 0.30 m³

 RASO 0.12 m³
À RAS BORD 0.12 m³

 COLMO 0.20 m³
NOMINALE 0.20 m³

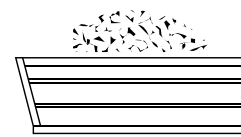
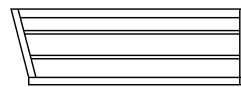
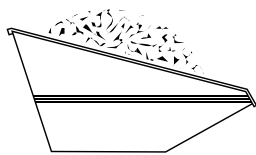
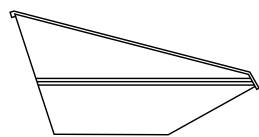

 RASO 0.21 m³
À RAS BORD 0.21 m³

 COLMO 0.29 m³
NOMINALE 0.29 m³

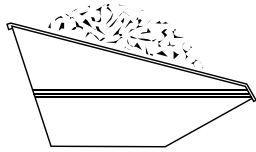
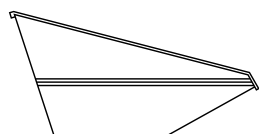

CAPACITÀ / CAPACITÉ