

T45

450 kg · 450 kg

IT Il minidumper T45 con portata massima di 450 kg è la macchina professionale più piccola della gamma. Basso pressione al suolo e ridottissime dimensioni consentono a questa macchina di lavorare negli spazi più stretti e su ogni terreno.

FR Le minidumper T45 avec une capacité maximale de 450 kg représente la plus petite machine professionnelle de la gamme. Sa basse pression au sol et ses dimensions très réduites permettent à cette machine d'intervenir dans des espaces plus étroits et sur tous les terrains.

Sovraspanda
Rallonge



Equipaggiato con / Équipé de :
Honda 5.5 HP



3



SL



A

1

Motorizzazione benzina
Moteur à essence

2

Avviamento manuale o elettrico
Démarrage manuel ou électrique

3

Due pompe idrauliche a ingranaggi
Deux pompes hydrauliques à engrenages

4

Trasmissione idrostatica
Transmission hydrostatique

5

Rulli oscillanti
Rouleaux oscillants

VANTAGGI / AVANTAGES

Maniglia ergonomica e sicura
Poignée ergonomique et sécurisée



Rulli oscillanti
Rouleaux oscillants

T45

MINIDUMPER

CAPACITÀ OPERATIVA
CAPACITÉS DE FONCTIONNEMENT
450 kg · 450 kg

LARGHEZZA AI CINGOLI
LARGEUR DES CHENILLES
680 mm · 680 mm

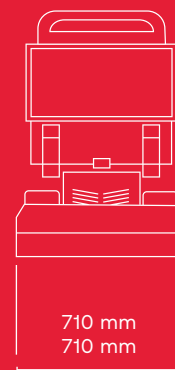
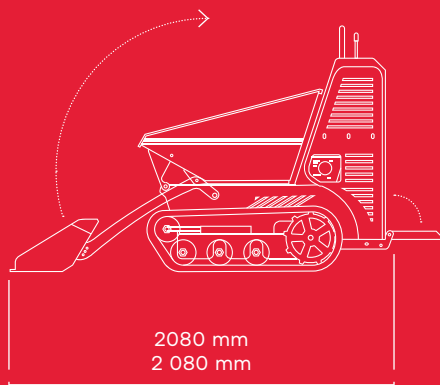
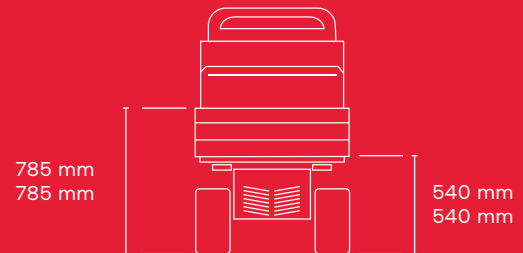
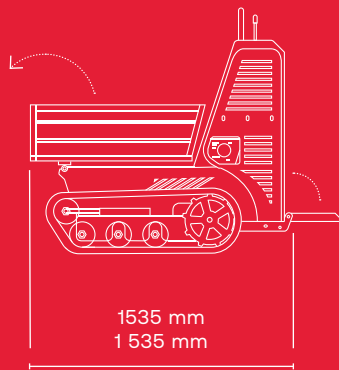
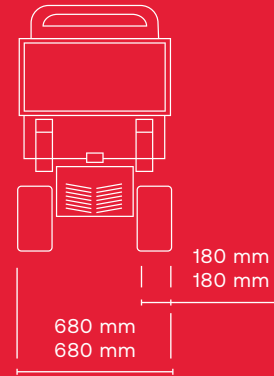
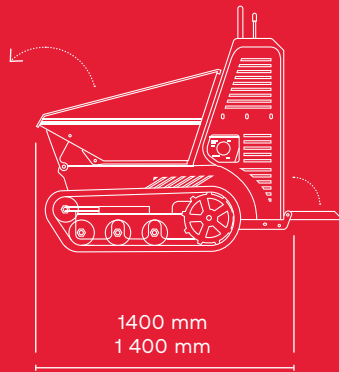

MOTORE TERMICO
MOTEUR THERMIQUE

→ **HONDA GX200**

TRASMISSIONE
TRANSMISSION

→ **IDROSTATICA**
→ **HYDROSTATIQUE**

POMPA IDRAULICA
POMPE HYDRAULIQUE

2 x INGRANAGGI
2 ENGRENAGES

MOTORE IDRAULICO
MOTEUR HYDRAULIQUE

2 x ORBITALI
2 ORBITAUX

PORTATA POMPA
DÉBIT POMPE

2 x 14 l/min
2 x 14 l/min

PRESSIONE MASSIMA
PRESSION MAXIMALE

180 bar
180 bars

RAFFREDDAMENTO IDRAULICO
REFROIDISSEMENT HYDRAULIQUE

ARIA
AIR

LARGHEZZA CINGOLI
LARGEUR CHENILLES

180 mm
180 mm

RULLI
ROULEAUX

3

RULLI OSCILLANTI
ROULEAUX OSCILLANTS

→ **SI**
→ **OUI**

REGOLAZIONE CINGOLI
RÉGLAGE CHENILLES

SI
OUI

1 VELOCITÀ DI TRASLAZIONE
1 VITESSE DE TRANSLATION

2.5 km/h
2.5 km/h

CAPACITÀ OPERATIVA
CAPACITÉS DE FONCTIONNEMENT

→ **450 KG**
→ **450 KG**

MASSA A VUOTO
POIDS À VIDE

340 kg
340 kg

CARATTERISTICHE TECNICHE / CARACTÉRISTIQUES TECHNIQUES

 **RASO 0.22 m³**
À RAS BORD 0.22 m³

 **COLMO 0.29 m³**
NOMINALE 0.29 m³

 **RASO 0.15 m³**
À RAS BORD 0.15 m³

 **COLMO 0.23 m³**
NOMINALE 0.23 m³

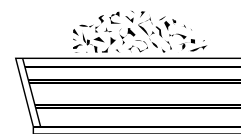
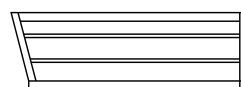
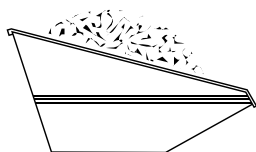
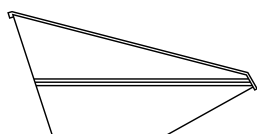

CAPACITÀ / CAPACITÉ