

T150

1500 kg · 1 500 kg

IT T150 è un Multi-tool che consente di cambiare equipaggiamento in pochi minuti. Progettata per utilizzo “heavy duty” trova applicazione nel mondo delle costruzioni e in tutti i settori caratterizzati da grande mole di lavoro. Macchina instancabile e precisa grazie a motorizzazioni potenti e sistema di controllo idraulico con mono-joystick.

FR Le T150 est un multi-tool qui permet de changer d'équipement en quelques minutes. Conçu pour une utilisation « intensive », il trouve son application dans le monde de la construction et dans tous les secteurs caractérisés par une charge de travail importante. Machine infatigable et précise grâce à son puissant moteur et à un système de contrôle hydraulique avec un levier de commande unique.



T150 • MINIJUMPER MULTI-OUTIL

CNF—ÉQUIPEMENT DE CONSTRUCTION

5



1 Sistema di sgancio rapido Système de déverrouillage rapide	2 Raffreddamento a liquido Refroidissement par liquide	3 Raffreddamento olio idraulico Refroidissement huile hydraulique
4 Trasmissione idrostatica Transmission hydrostatique	5 Rulli oscillanti Rouleaux oscillants	6 Motore diesel Yanmar da 25 hp Moteur diesel Yanmar de 25 hp

7 – EN OPTION

Presenza di forza 50 lt/min
 Prise de force 50 L/min

VANTAGGI / AVANTAGES



A
 —
 Centraggio conico
 Centrage conique



B
 —
 Motoriduttore con freno idraulico
 Motoréducteur avec frein hydraulique



C
 —
 Tendicingolo a grasso
 Tendeur à graisse



D
 —
 Connessione idraulica protetta
 Raccord hydraulique protégé



E
 —
 Doppie rulli oscillanti
 Rouleaux oscillants doubles



F
 —
 Bloccaggio rapido attrezzature
 Serrage rapide des outils





T150

MULTI-TOOL

CAPACITÀ OPERATIVA
CAPACITÉS DE FONCTIONNEMENT
1500 kg / 1 500 kg

LARGHEZZA AI CINGOLI
LARGEUR DES CHENILLES
940 mm / 940 mm

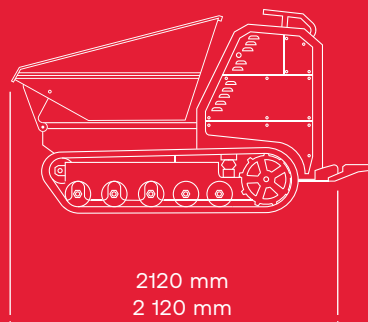
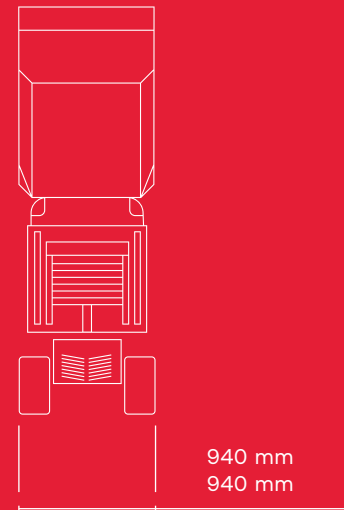
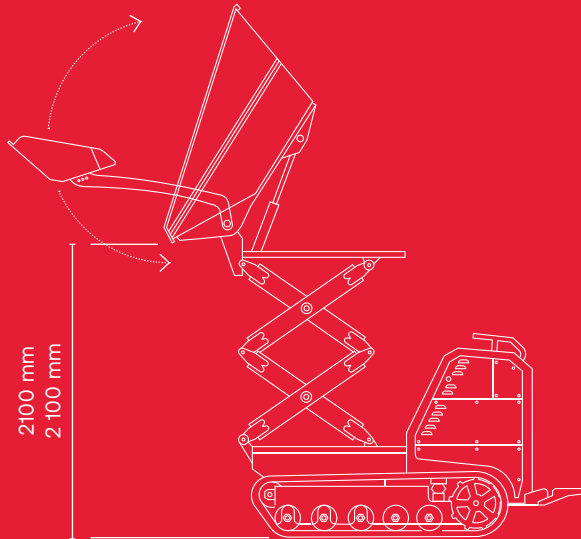
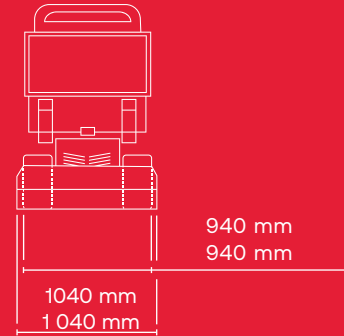
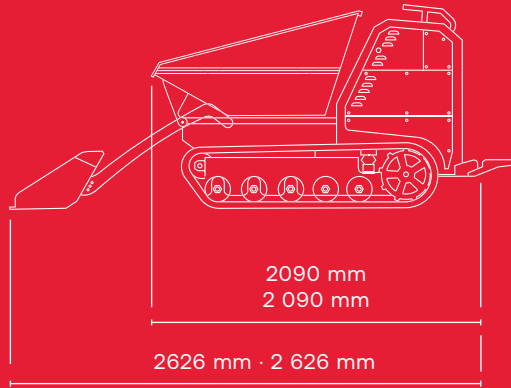

MOTORE TERMICO
MOTEUR THERMIQUE
→ **YANMAR 3TNV-80**

TRASMISSIONE
TRANSMISSION
→ **IDROSTATICA**
→ **HYDROSTATIQUE**

POMPA IDRAULICA
POMPE HYDRAULIQUE
→ **2 PORT. VARIABILI + INGR.**
→ **2 DÉBITS VARIABLES + ENGR.**

MOTORE IDRAULICO
MOTEUR HYDRAULIQUE
2 x MOTORIDUTTORI
2 MOTORÉDUCTEURS

PORTATA POMPA
DÉBIT POMPE
→ **2 x 56 l/min + 1 POMPA INGR.**
→ **2 x 56 l/min + 1 POMPE À ENGR.**

PRESSIONE MASSIMA
PRESSION MAXIMALE
180 bar
180 bars

RAFFREDDAMENTO IDRAULICO
REFROIDISSEMENT HYDRAULIQUE
LIQUIDO
LIQUIDE

LARGHEZZA CINGOLI
LARGEUR CHENILLES
200 · 230 mm

RULLI
ROULEAUX
→ **5**

RULLI OSCILLANTI
ROULEAUX OSCILLANTS
SI
OUI

REGOLAZIONE CINGOLI
RÉGLAGE CHENILLES
SI
OUI

VELOCITÀ DI TRASLAZIONE
VITESSES DE TRANSLATION
6 km/h
6 km/h

CAPACITÀ OPERATIVA
CAPACITÉS DE FONCTIONNEMENT
→ **1500 kg / 1 500 kg**
EXTRÉMITÉ
→ **1000 kg / 1 000 kg**

MASSA A VUOTO
POIDS À VIDE
950 · 1000 kg
950 · 1 000 kg

CONTROLLO
CONTRÔLE
→ **LEVIER DE COMMANDE UNIQUE**
DOPPIA LEVA (OPZIONALE)
DOUBLE LEVIER (EN OPTION)

CARATTERISTICHE TECNICHE / CARACTÉRISTIQUES TECHNIQUES

 **RASO 0.50 m³**
À RAS BORD 0.50 m³

 **COLMO 0.65 m³**
NOMINALE 0.65 m³

 **RASO 0.38 m³**
À RAS BORD 0.38 m³

 **COLMO 0.5 m³**
NOMINALE 0.5 m³

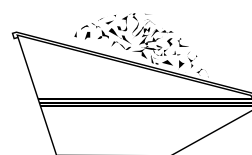
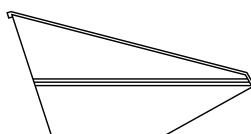
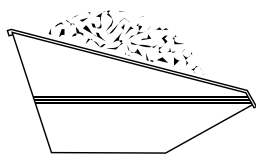
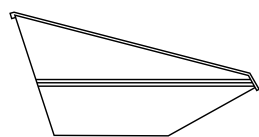

CAPACITÀ / CAPACITÉ

› QUICK ATTACH



Quick attach è il sistema che permette di cambiare la funzione della macchina in maniera rapida e sicura.

Quick attach (fixation rapide) est le système qui vous permet de changer la fonction de la machine, rapidement et en toute sécurité.

Versioni disponibili · Versions disponibles

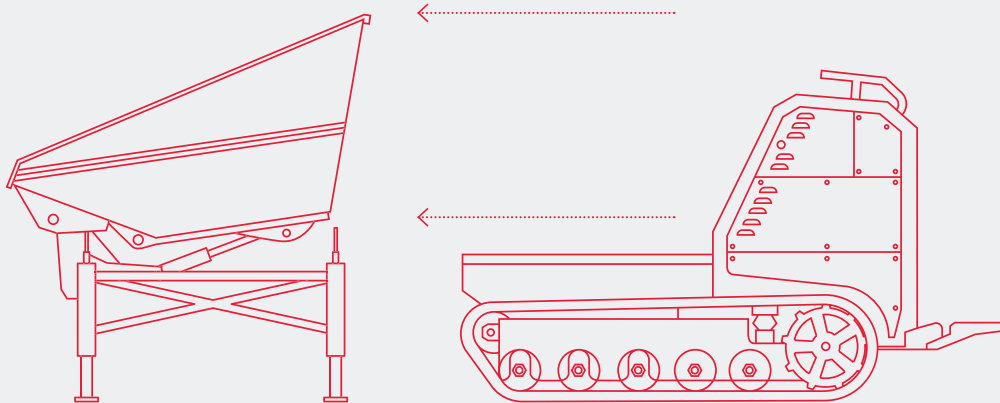

T150
YANMAR 3TNV80
25 hp - 18,6 kW

Indicatore di livello olio idraulico
Indicateur de niveau d'huile
hydraulique



Alloggiamento innesti rapidi
Boîtier pour raccords rapides

Motoriduttori
Motoréducteur





Maniglia operatore
Poignée opérateur

Regolazione tensione cingoli con pistone a grasso
Règlage tension chenilles avec piston à graisse

Doppi rulli oscillanti
Rouleaux oscillants doubles

Cassone alta capacità
Conteneur à grande capacité

Sovraspanda imbullonata
Porte-à-faux boulonné



Pedana reclinabile
Repose-pieds
inclinable



