

E95

**DUMPER
ÉLECTRIQUE**

**900 KG
900 KG**

IT Unico sul mercato, il Traker E95 è il modello dalle prestazioni e caratteristiche senza eguali. Trasportare fino a 900 kg di materiale non è mai stato così facile. La doppia pompa a portata variabile con mono-joystick rende questa macchina potente e facile da governare, riduce i consumi ed azzerava gli interventi di manutenzione. Il mezzo ideale per grandi carichi di lavoro e flotte noleggio.

FR Unique sur le marché, le Traker E95 représente un modèle avec des performances et caractéristiques sans précédent. Il n'a jamais été aussi facile de transporter jusqu'à 900 kg de matériel. La double pompe à débit variable avec levier de commande unique rend cette machine puissante et facile à diriger, elle réduit la consommation et élimine les interventions de maintenance. Le moyen idéal pour les charges de chantier lourdes et les flottes de location.

Sovraspanda
Rallonge



Sottocarro rinforzato
Châssis porteur renforcé

Joystick



Cofano posteriore con apertura laterale
per facilitare gli interventi di manutenzione
Capot arrière avec ouverture latérale
pour faciliter les interventions de maintenance

T95 • MINIDUMPER

CNF—ÉQUIPEMENT DE CONSTRUCTION

6



SL



HT



HTSL



A



SW

Versioni disponibili • Versions disponibles

1

Due pompe port. var. + 1 pompa ingr.
Deux pompes à débit var. + 1 pompe
à engr.

2

Trasmissione idrostatica
Transmission hydrostatique

3

Rulli oscillanti
Rouleaux oscillants

VANTAGGI / AVANTAGES

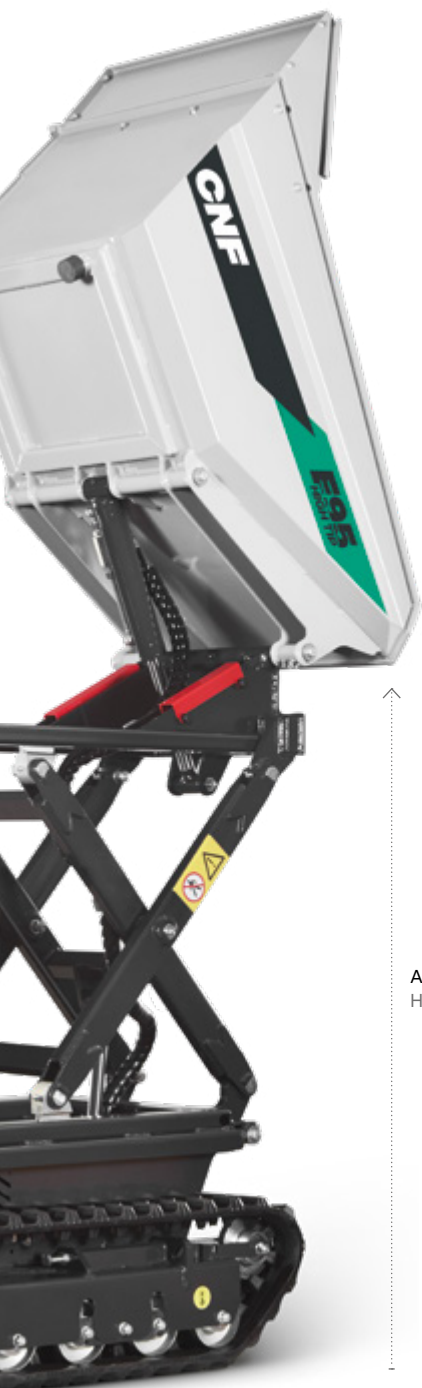

Cassone con sponde apribili
Conteneur avec ridelles ouvrantes



Altezza max 1420 mm
Hauteur max 1 420 mm



Pedana ammortizzata
Plateau d'amortissement

E95

MINIDUMPER

CAPACITÀ OPERATIVA
CAPACITÉS DE FONCTIONNEMENT
900 KG · 900 KG

LARGHEZZA AI CINGOLI
LARGEUR DES CHENILLES
780 MM · 780 MM

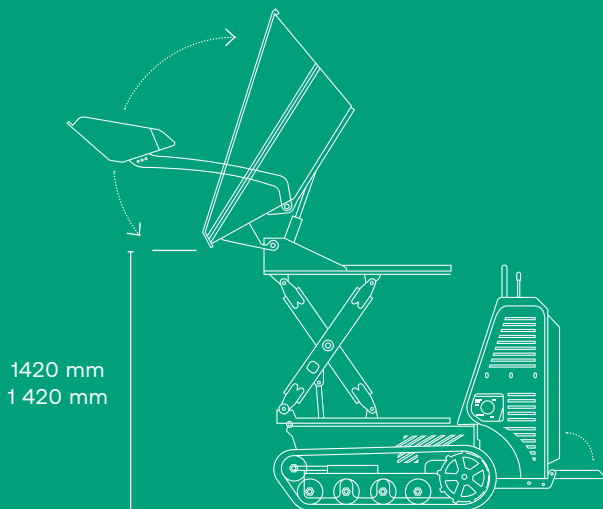
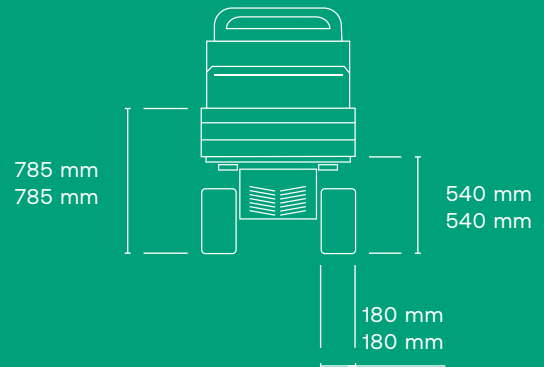
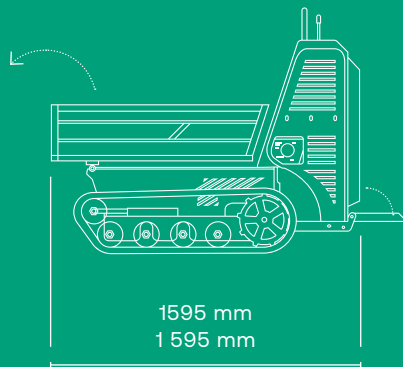
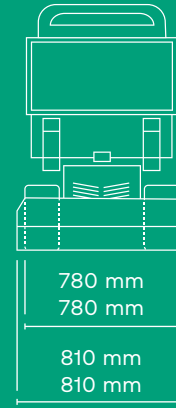
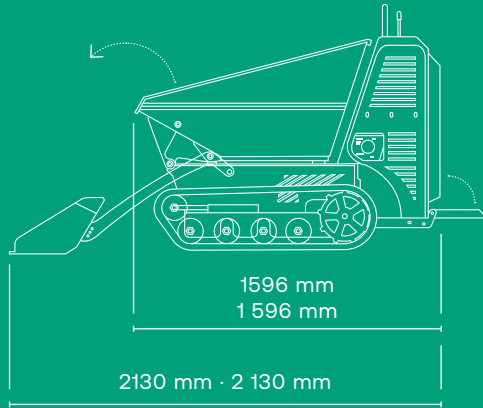

VOLTAGGIO BATTERIA
TENSION DE LA BATTERIE
→ 80 V

TRASMISSIONE
TRANSMISSION
→ IDROSTATICA
→ HYDROSTATIQUE

CAPACITÀ BATTERIA
CAPACITÉ DE LA BATTERIE
→ 8 KWH

MOTORE IDRAULICO
MOTEUR HYDRAULIQUE
2 x ORBITALI
2 ORBITAUX

PORTATA POMPA
DÉBIT POMPE
→ 2x32 L/MIN + 1 POMPA INGR
→ 2x32 L/MIN + 1 POMPE À ENGR.

PRESSIONE MASSIMA
PRESSION MAXIMALE
180 bar
180 bars

TEMPO DI RICARICA
TEMPS DE RECHARGE
5 H

LARGHEZZA CINGOLI
LARGEUR CHENILLES
180 mm
180 mm

RULLI
ROULEAUX
→ 4

RULLI OSCILLANTI
ROULEAUX OSCILLANTS
SI
OUI

REGOLAZIONE CINGOLI
RÉGLAGE CHENILLES
SI
OUI

VELOCITÀ MASSIMA
VITESSE MAXIMALE
4 km/h
4 km/h

CAPACITÀ OPERATIVA
CAPACITÉS DE FONCTIONNEMENT
→ 900 KG / 900 KG
EXTRÉMITÉ
→ 800 KG / 800 KG

MASSA A VUOTO
POIDS À VIDE
500 kg
500 kg

CONTROLLO
CONTRÔLE
→ LEVIER DE COMMANDE UNIQUE

CARATTERISTICHE TECNICHE / CARACTÉRISTIQUES TECHNIQUES

 RASO 0.30 m³
À RAS BORD 0.30 m³

 COLMO 0.36 m³
NOMINALE 0.36 m³

 RASO 0.17 m³
À RAS BORD 0.17 m³

 COLMO 0.25 m³
NOMINALE 0.25 m³

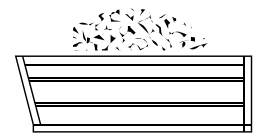
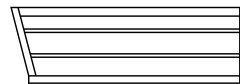
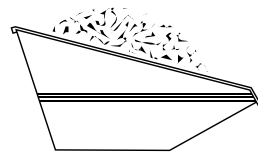
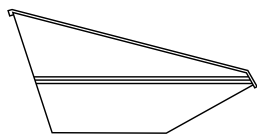

 RASO 0.28 m³
À RAS BORD 0.28 m³

 COLMO 0.36 m³
NOMINALE 0.36 m³

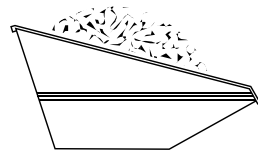
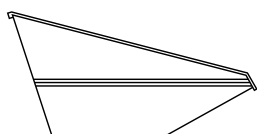

CAPACITÀ / CAPACITÉ