

**CNF**



IT-EN

**E•TRAKER**

**IT** I minidumper elettrici di CNF sono stati pensati per soddisfare anche i clienti più esigenti, offrendo caratteristiche tecniche e comfort di guida senza eguali. Nessun gas di scarico e ridotte emissioni acustiche permettono di lavorare all'interno di edifici e/o aree sensibili ad alti livelli di rumorosità tutelando tuttavia la salute e la sicurezza dell'operatore.

L'architettura della batteria consente lunghi cicli di lavoro e brevi tempi di ricarica senza degrado delle prestazioni. Un pannello di controllo 12" a colori offre la possibilità all'utilizzatore di scegliere tra 5 differenti velocità e controllare il livello di carica della batteria.

Le macchine perfette per rivenditori, noleggiatori, aziende specializzate nella paesaggistica e nel giardinaggio, come aziende agricole e restauratori.

**EN** CNF electric minidumpers are engineered to satisfy the most demanding customers, offering technical features and driving comfort beyond compare. The elimination of exhaust gases and low noise emissions makes it possible to work inside high-noise buildings and/or sensitive areas without compromising the operator's health and safety.

The special battery design allows long duty cycles and short charge times without any reduction in performance. A 12" colour control panel allows the user to choose between 5 different speeds and monitor the battery charge level.

E-Trakers are the ideal machines for dealers, hirers, landscaping and gardening companies, farms and restorers.



**CICLO DI LAVORO  
DUTY CYCLE**



Al massimo delle sue prestazioni il dumper è in grado di eseguire cicli completi di lavoro per oltre 5 ore.  
At peak performance, the dumper has a duty cycle of more than 5 hours.

**RICARICA SEMPLICE  
SIMPLE CHARGING**



Il minidumper si ricarica in sole 4 ore se collegato ad una semplice presa elettrica 220V. Il cavo è fornito con la dotazione di serie e riposto all'interno del cofano motore.  
The minidumper recharges in just 4 hours if connected to a simple 220V power outlet. The cable is supplied standard and housed inside the motor bonnet.

**BATTERIA  
BATTERY**



Il pacco batterie agli ioni di litio non necessita alcuna manutenzione e permette di risparmiare sui costi di mantenimento della macchina. L'assenza di "effetto memoria" permette di ricaricare anche parzialmente la macchina.  
The lithium-ion battery pack is maintenance-free, thus reducing machine operating costs. The lack of "memory effect" allows even partial charging of the battery.

**CARICA BATTERIE  
BATTERY CHARGER**



L'equipaggiamento della macchina prevede di serie un caricabatterie dedicato. È possibile in questo modo effettuare una carica completa in meno di 4 ore anche sul cantiere.  
The machine is supplied standard with a dedicated battery charger. This allows full battery charging in less than 4 hours, even on site.

**PUNTI DI FORZA / STRENGTHS**

|   |   |   |
|---|---|---|
| <p><b>1</b></p> <p>Nessuna emissione di gas di scarico<br/>No exhaust emissions</p> | <p><b>2</b></p> <p>Ridotte emissioni acustiche<br/>Reduced noise emissions</p>      | <p><b>3</b></p> <p>Elevata autonomia delle batterie<br/>High battery run time</p> |
| <p><b>4</b></p> <p>Dimensioni estremamente ridotte<br/>Extremely compact size</p>   | <p><b>5</b></p> <p>Nessun effetto memoria batterie<br/>No battery memory effect</p> | <p><b>6</b></p> <p>Ricarica batterie rapida<br/>Fast battery charging</p>         |

**VANTAGGI / BENEFITS**

# E70

**700 KG  
1543 LBS**

**IT** Grande potenza idraulica a tre stadi e ridotte dimensioni permettono al minidumper E70 di trasportare facilmente carichi fino a 700 kg attraverso qualsiasi passaggio. La macchina ideale per essere utilizzata su cantieri edili, giardinaggio, agricoltura e garden design.

**EN** A great three stage hydraulic power and compact dimensions ensure to E70 minidumper to carry easily up to 1543 lbs loads through every tight passage. The ideal machine to be used in construction sites, landscaping, agriculture or garden design.

Sistema autocaricante  
Self-loading system



Sottocarro rinforzato  
Heavy duty undercarriage

Equipaggiato con / Equipped with:  
Honda 8,4 HP

Joystick



Cassone con sponde apribili  
Farm bed skip



Sovraspanda  
Extra overboard



**1**

Due pompe port. var. + 1 pompa ingr.  
Two var. displ. pumps + 1 gear pump

**2**

Trasmissione idrostatica  
Hydrostatic transmission

**3**

Rulli oscillanti  
Rocking rollers

**VANTAGGI / ADVANTAGES**

**5**



Versioni disponibili · Available models

E70 • ELECTRIC MINIDUMPER

CNF-CONSTRUCTION EQUIPMENT

CNF-CONSTRUCTION EQUIPMENT

E70 • ELECTRIC MINIDUMPER

**7**

# E70

## MINIDUMPER

**CAPACITÀ OPERATIVA  
OPERATING WEIGHT**  
700 KG · 1543 LBS

**LARGHEZZA AI CINGOLI  
TRACK WIDTH**  
680 MM · 26.7 INCH

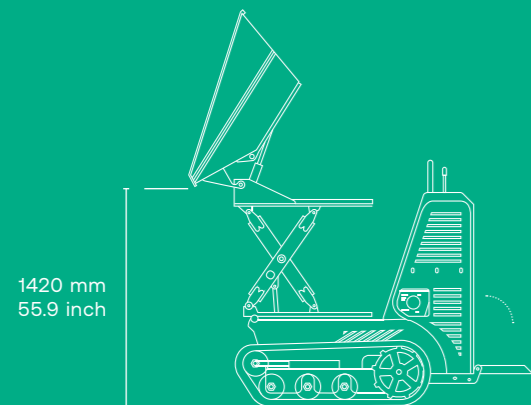
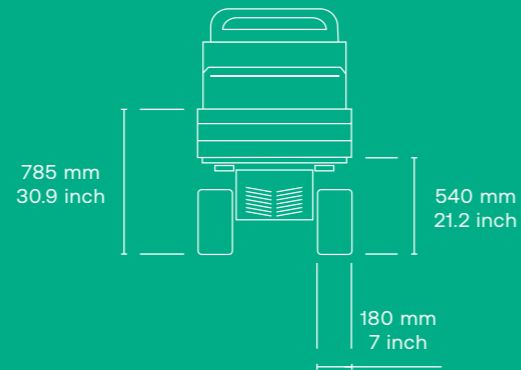
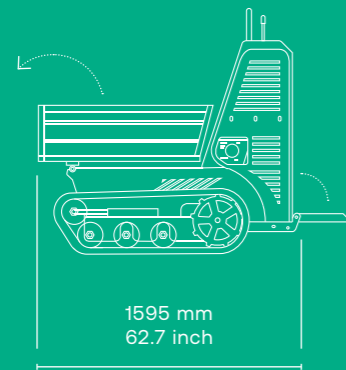
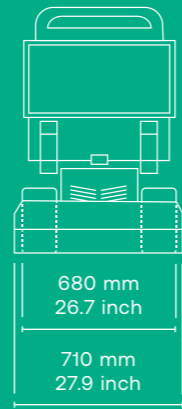
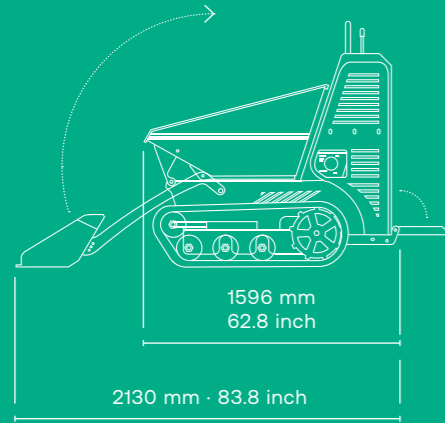

**VOLTAGGIO BATTERIA  
BATTERY VOLTAGE**  
→ 80 V

**TRASMISSIONE  
TRANSMISSION**  
→ IDROSTATICA  
→ HYDROSTATIC

**CAPACITÀ BATTERIA  
BATTERY CAPACITY**  
→ 8 KWH

**MOTORE IDRAULICO  
HYDRAULIC MOTOR**  
2 x ORBITALI  
2 x ORBITAL

**PORTATA POMPA  
PUMP FLOW RATE**  
→ 2x25 L/MIN + 1 POMPA INGR.  
→ 3x6 GPM + 1 GEAR PUMP

**PRESSIONE MASSIMA  
MAX PRESSURE**  
180 bar

**TEMPO DI RICARICA  
RECHARGE TIME**  
5 H

**LARGHEZZA CINGOLI  
TRACK WIDTH**  
180 mm  
7 inch

**RULLI  
TRACK ROLLERS**  
3

**RULLI OSCILLANTI  
ROCKING ROLLERS**  
→ SI  
→ YES

**REGOLAZIONE CINGOLI  
TRACK TENSIONER**  
SI  
YES

**VELOCITÀ MASSIMA  
MAX SPEED**  
4 km/h  
2.5 mph

**CAPACITÀ OPERATIVA  
OPERATING WEIGHT**  
→ 700 KG / 1543 LBS  
**HIGH-TIP**  
→ 600 KG / 1322 LBS

**MASSA A VUOTO  
EMPTY WEIGHT**  
355 kg  
749 lbs

**CONTROLLO  
CONTROL**  
→ MONOJOYSTICK

### CARATTERISTICHE TECNICHE / TECHNICAL FEATURES

 RASO 0.24 m<sup>3</sup>  
STRUCK 0.31 yd<sup>3</sup>

 COLMO 0.30 m<sup>3</sup>  
HEAPED 0.39 yd<sup>3</sup>

 RASO 0.12 m<sup>3</sup>  
STRUCK 0.15 yd<sup>3</sup>

 COLMO 0.20 m<sup>3</sup>  
HEAPED 0.26 yd<sup>3</sup>

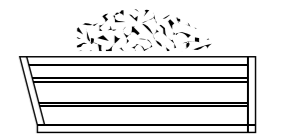
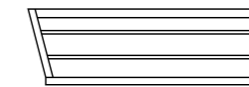
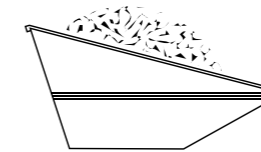
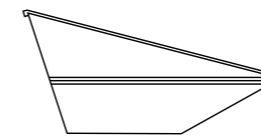

 RASO 0.21 m<sup>3</sup>  
STRUCK 0.27 yd<sup>3</sup>

 COLMO 0.29 m<sup>3</sup>  
HEAPED 0.37 yd<sup>3</sup>

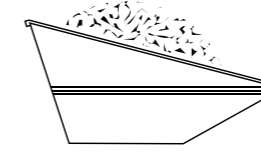
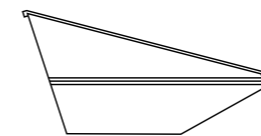

### CAPACITÀ / CAPACITY

# E95

**900 KG  
1984 LBS**

**IT** Unico sul mercato, il Traker E95 è il modello dalle prestazioni e caratteristiche senza eguali. Trasportare fino a 900 kg di materiale non è mai stato così facile. La doppia pompa a portata variabile con mono-joystick rende questa macchina potente e facile da governare, riduce i consumi ed azzerza gli interventi di manutenzione. Il mezzo ideale per grandi carichi di lavoro e flotte noleggio.

**EN** Unique of its kind, E95 minidumper has performances and features like no other. It's never been easier to carry up to 1984 lbs of material. The double variable-displacement pump with mono-joystick hydraulic control makes this machine powerful and easy-to-use, reducing consumption and eliminating maintenance. It's the ideal dumper for high-duty activities and rental fleets.

**1**

Due pompe port. var. + 1 pompa ingr.  
Two var. displ. pumps + 1 gear pump

**2**

Trasmissione idrostatica  
Hydrostatic transmission

**3**

Rulli oscillanti  
Rocking rollers

**VANTAGGI / ADVANTAGES**

Sovraspanda  
Extra overboard



Joystick

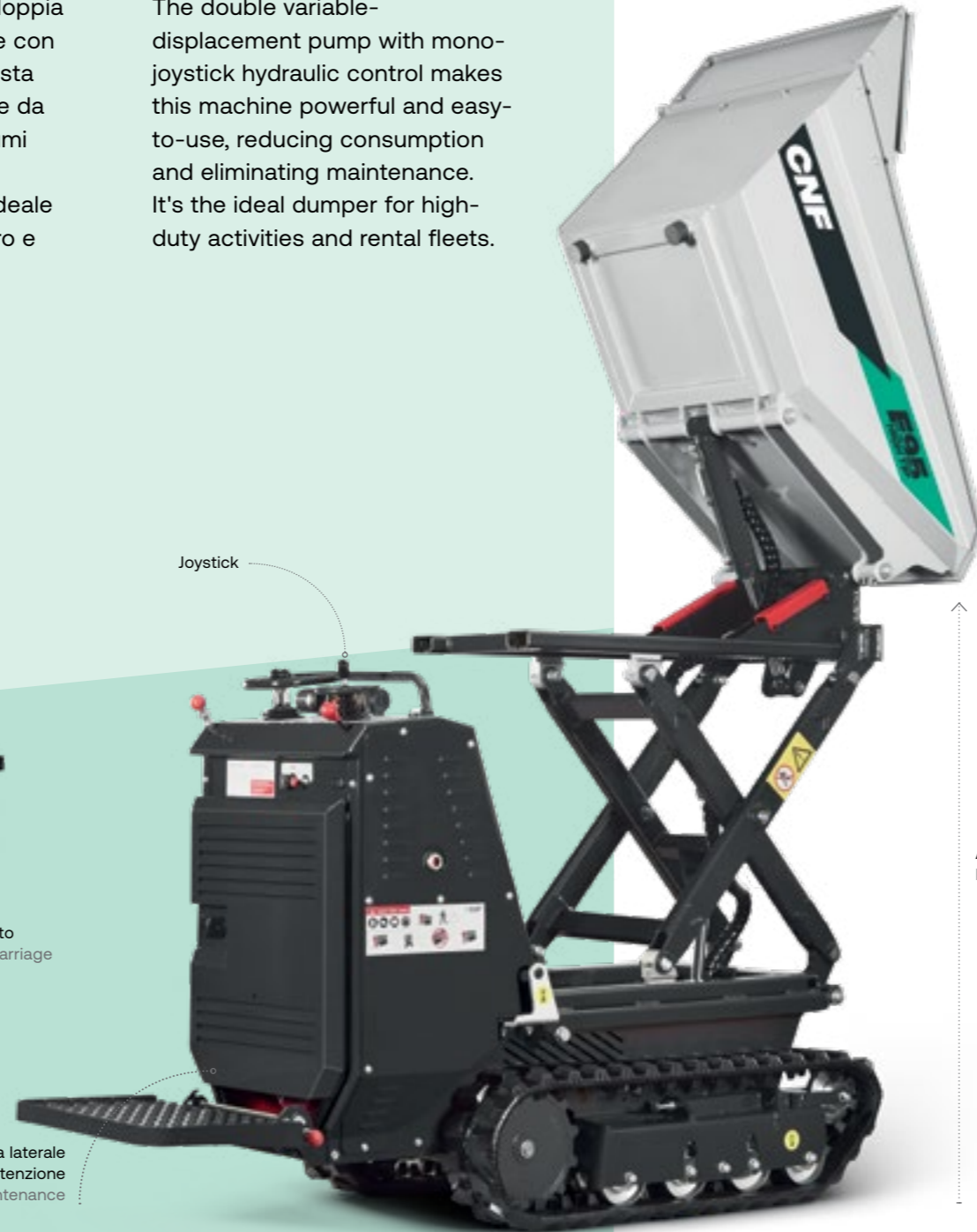

Sottocarro rinforzato  
Heavy duty undercarriage

Cofano posteriore con apertura laterale  
per facilitare gli interventi di manutenzione  
Engine cover with side opening to facilitate maintenance

Cassone con sponde apribili  
Farm bed skip



Altezza max 1420 mm  
Max height 55.9 inch



Pedana ammortizzata  
Soften foot-plate

**5**



Versioni disponibili · Available models

E95 • ELECTRIC MINIDUMPER

CNF-CONSTRUCTION EQUIPMENT

CNF-CONSTRUCTION EQUIPMENT

E95 • ELECTRIC MIN.

# E95

## MINIDUMPER

**CAPACITÀ OPERATIVA  
OPERATING WEIGHT**  
900 KG · 1984 LBS

**LARGHEZZA AI CINGOLI  
TRACK WIDTH**  
780 MM · 27.9 INCH

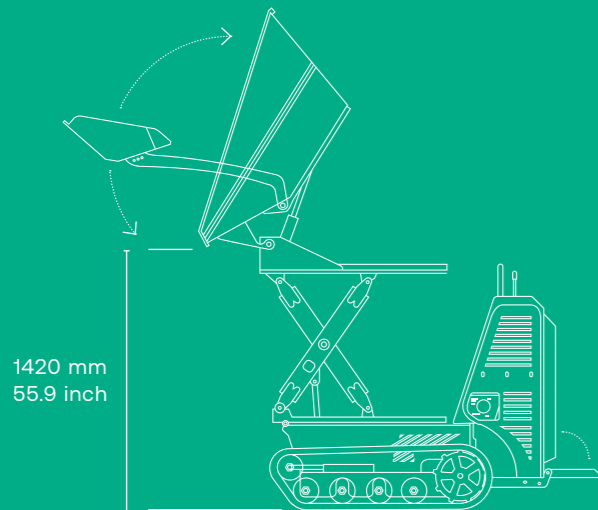
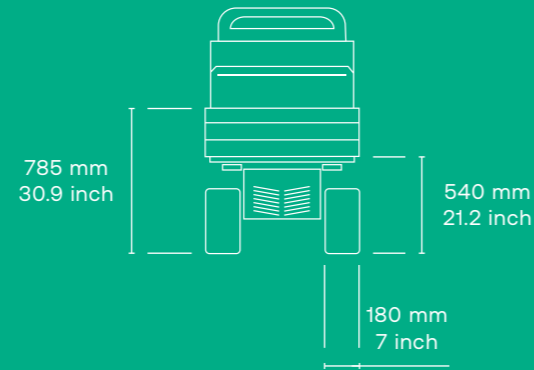
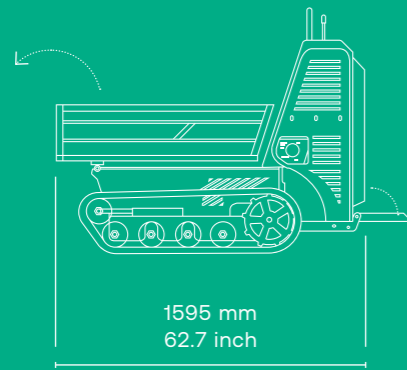
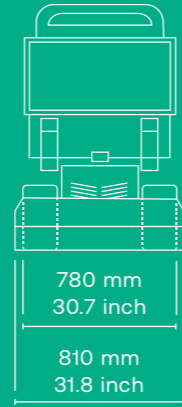
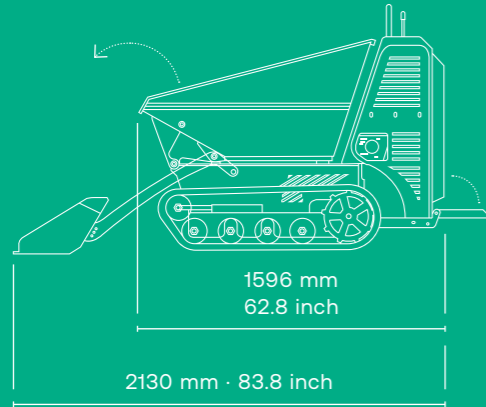

**VOLTAGGIO BATTERIA  
BATTERY VOLTAGE**  
→ 80 V

**TRASMISSIONE  
TRANSMISSION**  
→ IDROSTATICA  
→ HYDROSTATIC

**CAPACITÀ BATTERIA  
BATTERY CAPACITY**  
→ 8 KWH

**MOTORE IDRAULICO  
HYDRAULIC MOTOR**  
2 x ORBITALI  
2 x ORBITAL

**PORTATA POMPA  
PUMP FLOW RATE**  
→ 2x32 L/MIN + 1 POMPA INGR  
→ 2x8.5 GPM + 1 GEAR PUMP

**PRESSIONE MASSIMA  
MAX PRESSURE**  
180 bar

**TEMPO DI RICARICA  
RECHARGE TIME**  
5 H

**LARGHEZZA CINGOLI  
TRACK WIDTH**  
180 mm  
7 inch

**RULLI  
TRACK ROLLERS**  
→ 4

**RULLI OSCILLANTI  
ROCKING ROLLERS**  
SI  
YES

**REGOLAZIONE CINGOLI  
TRACK TENSIONER**  
SI  
YES

**VELOCITÀ MASSIMA  
MAX SPEED**  
4 km/h  
2.5 mph

**CAPACITÀ OPERATIVA  
OPERATING WEIGHT**  
→ 900 KG / 1984 LBS  
**HIGH-TIP**  
→ 800 KG / 1763 LBS

**MASSA A VUOTO  
EMPTY WEIGHT**  
500 kg  
1102 lbs

**CONTROLLO  
CONTROL**  
→ MONOJOYSTICK

### CARATTERISTICHE TECNICHE / TECHNICAL FEATURES

 RASO 0.30 m<sup>3</sup>  
STRUCK 0.39 yd<sup>3</sup>

 COLMO 0.36 m<sup>3</sup>  
HEAPED 0.45 yd<sup>3</sup>

 RASO 0.17 m<sup>3</sup>  
STRUCK 0.22 yd<sup>3</sup>

 COLMO 0.25 m<sup>3</sup>  
HEAPED 0.32 yd<sup>3</sup>

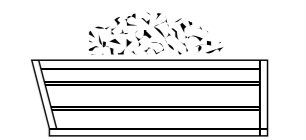
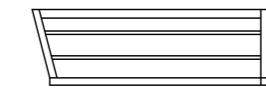
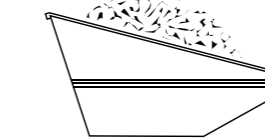
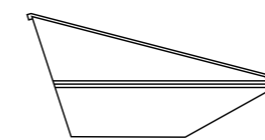

 RASO 0.28 m<sup>3</sup>  
STRUCK 0.37 yd<sup>3</sup>

 COLMO 0.36 m<sup>3</sup>  
HEAPED 0.47 yd<sup>3</sup>

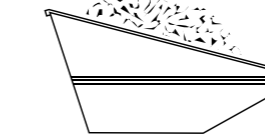
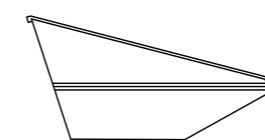

### CAPACITÀ / CAPACITY





**C&F SRL**

Viale Finlandia 8  
73100 Lecce, IT  
VAT 036 19 66 07 50  
+39 0832 24 39 60

**[www.cnf-ce.com](http://www.cnf-ce.com)**  
**[info@cnf-ce.com](mailto:info@cnf-ce.com)**